



Champion Motors

SUZUKI SHOWROOM

10 Chang Charn Road #01-00,
Link (THM) Building,
Singapore 159639

 6631 1118

 www.suzukicar.com.sg

 Suzuki.SG

 [suzukicarsg](https://www.instagram.com/suzukicarsg)

GONE IN A JIMMY



EXTERIOR DESIGN

STRONG BODY BUILT FOR ROUGH TERRAIN



LED HEADLAMPS



HEADLAMPS WASHERS



15-INCH ALLOY WHEEL



The upright A-pillars provide clearer view of the bonnet edges for better grasping of the vehicle position.



Upright windshield and longer roof help the driver avoid direct sunlight.



Dipped front window lines expand visibility from the side window



Rear fog lamp
Turn lamps
Brake/tail lamps
Reverse lamp

BODY STRUCTURE

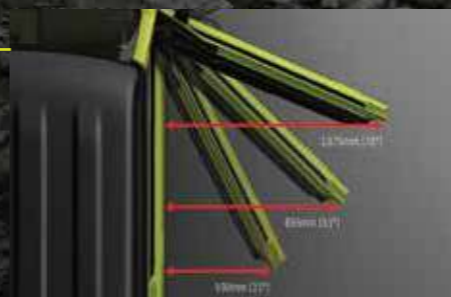

FRONT DOOR OPENING



DRIP RAIL

The drip rail running along the side and rear edges of the roof provides edges for flexible installing of roof carriers. Together with the new Jimny's square body, the rail allows efficient use of the wider roof area and prevents water from dripping onto passengers.

HISTORY

The new Jimny fully embodies the core concept of a “small, lightweight 4WD SUV” behind nearly 50 years of worldwide popularity.

Born in April 1970, the Jimny soon became a game changer in the 4WD market, which until then had been dominated by large, high-displacement vehicles. Loved around the world from the very beginning, it underwent full model changes only twice in its nearly 50 years of history. The new Jimny carries on the heritage of a small, lightweight automatic off-roader and is a masterpiece of Suzuki 4WD technology.

1ST GENERATION
1970 - 1981



2ND GENERATION
1981 - 1998



3RD GENERATION
1998 - 2018



4TH GENERATION
2018 - PRESENT



INTERIOR DESIGN

EASY

HANDLING

BLACK INTERIOR WITH INDICATIVE COLOURS



METER CLUSTER



HAIRLINE FINISHED METER CLUSTER GARNISH



FLOOR CONSOLE TRAY



RIDE-IN ASSIST GRIP

■ Unlike the D-shaped steering wheels in sports-type models, the steering wheel in the Jimny is circular to maintain ease of handling in rough, off-road terrain.

■ It can also be vertically adjusted up to 35mm.

SCRATCH/STAIN-RESISTANT GRAINS

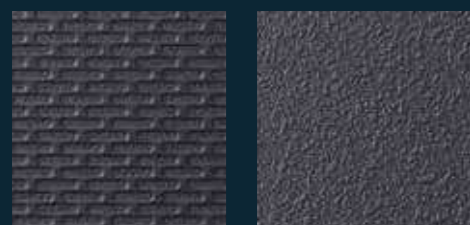

INTUITIVELY DESIGNED CONTROLS

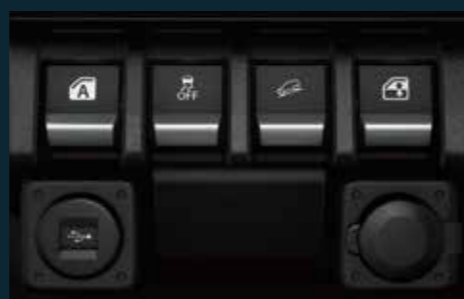

CENTRE CONSOLE TRAY



FRONT SEAT AREA

Specially designed for professional use.

LUGGAGE SPACE

VERTICAL PILLARS

HELP INCREASE
LOAD VOLUME



The rear lamps are all gathered on the bumper to make room for a wider rear door opening.



SEATS RAISED 85L



1 REAR SEAT FOLDED 377L



BOTH REAR SEAT FOLDED
830L

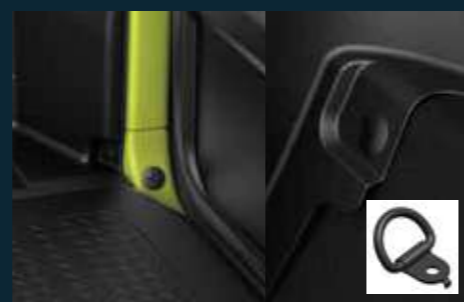

LUGGAGE HOOK
SCREW HOLES

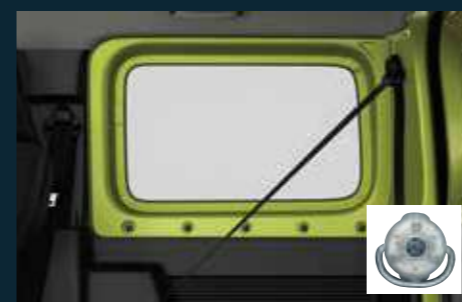

UTILITY SCREW HOLES



LUGGAGE BOX



TOOLBOX

OFF-ROAD PERFORMANCE

STRONGER & MORE ROBUST HIGH-TENSILE STEEL

3-LINK RIGID AXLE SUSPENSION WITH COIL SPRING



LADDER FRAME NEW "X-MEMBER" & TWO ADDITIONAL CROSS MEMBERS

Two cross members near the centre of the ladder frame forms an X-shaped reinforcement that increases torsional rigidity. This helps provide a more solid base for underbody parts to achieve intended suspension performance, contributing to everyday driving, riding comfort on the road, as well as a solid off-road ride.

BODY MOUNTS

The eight rubber body mounts positioned between the ladder frame and upper body have been redesigned to enhance ride comfort and sure driving.



THREE ANGLES

The ample approach angle, ramp breakover angle and departure angle allow the Jimny to climb over obstacles and steep hills without scraping its bumpers or underbody.

GROUND CLEARANCE

Ground clearance has been increased to 210mm (+10mm) to provide enough height to tackle even the toughest terrain.

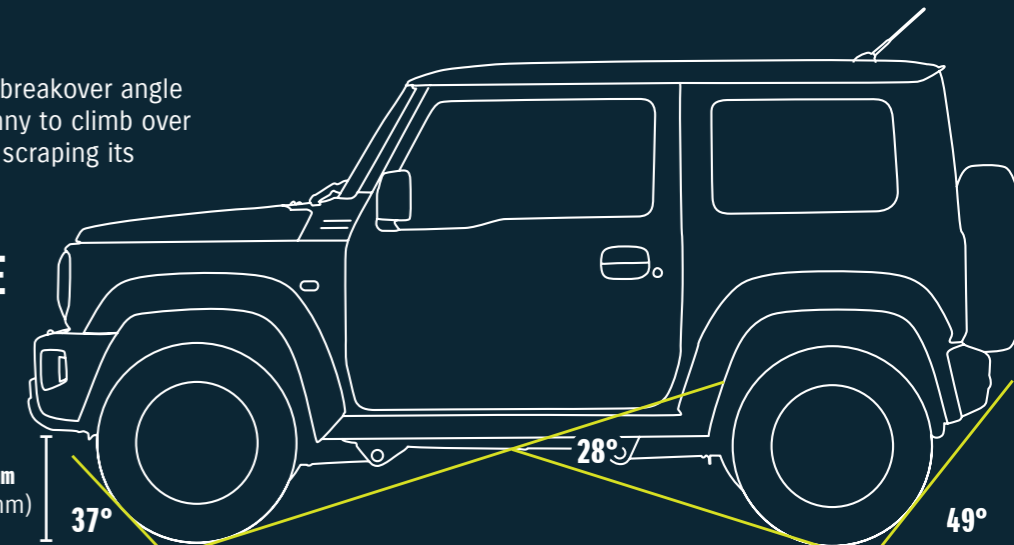

ENGINE (K15B)



FUEL EFFICIENCY WITH BETTER PERFORMANCE

The new Jimny adopts a K15B engine that is lightweight, compact and fuel efficient. It delivers stronger torque at all rpm than the old jimny, with ample torque at low revolution, maintaining off-road driving performance as well as enhanced fuel efficiency.

ALLGRIP PRO

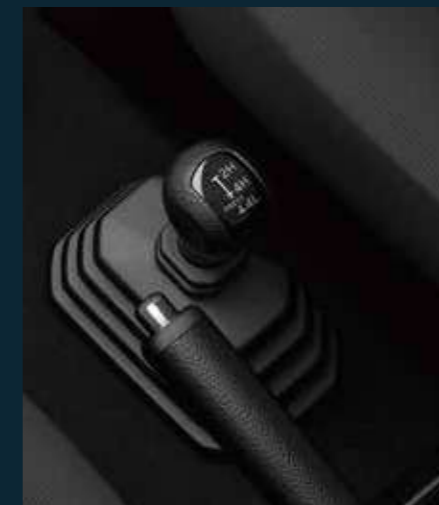

4WD WITH LOW RANGE TRANSFER GEAR

The Jimny can be switched between 2H (2WD-high gear), 4H (4WD-high gear) and 4L (4WD-low gear) modes by a shift lever directly connected to the transfer gear.

- **2H** Offers smoother, more efficient driving in the city and on highways.
- **4H** Enables sure driving off-road and in the snow.
- **4L** Show the Jimny's true potential when travelling over rough rocks, mud and unbeaten tracks.



4-SPEED AUTOMATIC TRANSMISSION

The refined 4-speed automatic transmission reduces friction and enhance fuel efficiency. The shift pattern has been changed from the current gate type to the aligned type for simple operations.

SAFETY FEATURES

PEDESTRIAN INJURY MITIGATING BODY

The bonnet and its surrounding parts absorb impact to mitigate head and leg injuries in the event of a collision with a pedestrian.



DUAL SENSOR BRAKE SUPPORT (DSBS)

When moving, the new Jimny uses a monocular camera sensor and laser sensor to evaluate the risk of a collision with vehicles. Upon detecting a potential collision, DSBS takes one or more of the following actions, depending on the situation.

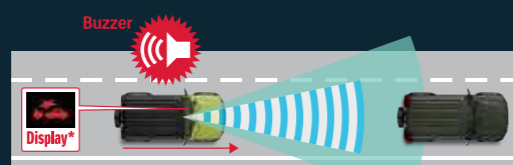

WARNING

Alerts the driver with an audio warning and visual warning

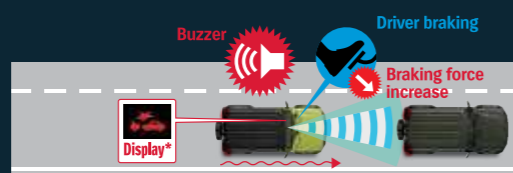

BRAKE ASSIST

Deploys brake assist to increase braking force if the risk of collision is high and the driver panics

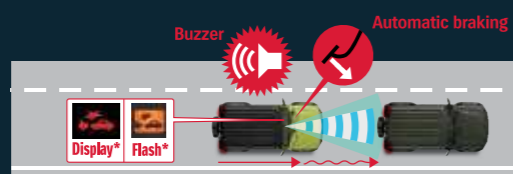

AUTOMATIC BRAKE

Applies strong automatic braking if the risk of collision increases even more

*Shown on the multi-information display



TOTAL EFFECTIVE CONTROL TECHNOLOGY (TECT)

The new Jimny's body design centres on Suzuki's TECT concept, resulting in a structure that efficiently absorbs and disperses energy in the event of a collision

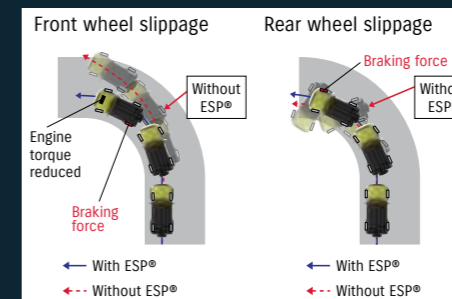

ESP®

If Electronic Stability Programme (ESP®)* detects wheel slippage, it automatically adjusts the engine torque and brakes to suppress wheel slippage and help the driver stay in directional control.

*ESP® is registered trademark of Daimler AG. Please refer to the equipment list for availability.

SMALL TURNING RADIUS

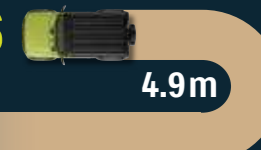

A minimum turning radius of 4.9 metres provides excellent manoeuvrability in places where larger vehicles require three-point turns.



6 AIRBAGS

LANE DEPARTURE WARNING



VEHICLE SWAY WARNING

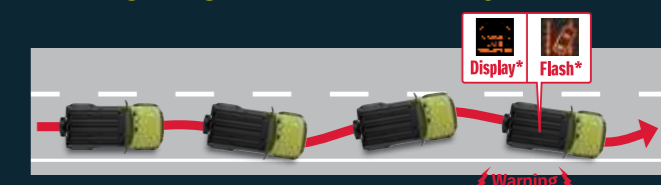

EMERGENCY STOP SIGNAL

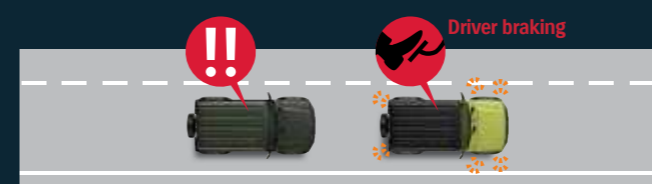

HIGH BEAM ASSIST

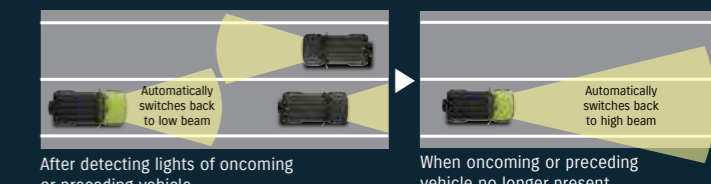

SPECIFICATIONS

DIMENSIONS AND WEIGHTS

Overall Length / Width / Height	mm	3,480 / 1,645 / 1,725
Wheelbase	mm	2,250
Min. Turning Radius	m	4.9
Ground Clearance	mm	210
Kerb Weight	kg	1,110

ENGINE AND TRANSMISSION

Engine Type		1.5L VVT Petrol
Capacity	cc	1,462
Max. Engine Output	kw (bhp) / rpm	75 (100)/6,000
Max. Torque	Nm / rpm	130/4,000
Transmission		4AT

PERFORMANCE

Top Speed	km / h	140
-----------	--------	-----

FUEL CONSUMPTION

Combined	litre/100km (km/litre)	6.7(14.4)
VES Banding		B

CHASSIS

Suspension	Front / Rear	3-link rigid axle with coil spring / 3-link rigid axle with coil spring
Brakes	Front / Rear	Solid disc / Drum, leading and trailing
Tyres		195/80R15

Addition of extra features may change figures in the chart • Suzuki Motors Corporation and Champion Motors (1975) Pte Ltd reserve the right to alter any details of specifications and equipment without notice • Vehicles pictured and specifications detailed in this catalogue may vary from models and equipment in your area • Actual interior features and colours may differ from pictures shown • Vehicle body colour might differ slightly from printed photos in this catalogue

EQUIPMENT

EXTERIOR

- LED Projector headlamps with washers
- Automatic headlamps
- Front fog lamp
- Rear combination lamps
- Electrical adjust wing mirrors
- 15" polished alloy wheels
- Drip rails

INTERIOR

- Multi-functional steering switches
- Ride-in assist grip
- Automatic air conditioning
- Cruise control
- Electric windows
- Adjustable Steering Wheel
- Floor console tray

SAFETY

- SRS dual front airbags
- SRS side airbags
- SRS curtain airbags
- Front passenger airbag deactivation system
- Vehicle Sway Warning
- Land Departure Warning
- High Beam Assist
- Hill hold control
- Hill Descent Control
- Electronic Stability Program (ESP®)
- Anti-lock Braking System (ABS)
- Dual Sensor Brake Support (DSBS)
- Emergency Stop Signal
- Brake Assist Function



BODY COLOURS



Kinetic Yellow +
Bluish Black Pearl 3 (DG5)



Brisk Blue Metallic +
Bluish Black Pearl 3 (CZW)



Chiffon Ivory Metallic +
Bluish Black Pearl 3 (2BW)



Jungle Green (ZJC)



Bluish Black Pearl 3 (ZJ3)



Medium Gray (ZVL)



Silky Silver Metallic (Z2S)



Superior White (26U)



Pure White Pearl (ZVR)