

Q50



INFINITI

EMPOWER THE DRIVE

INFINITE POTENTIAL

We believe every driver is empowered with untold possibilities. To excel. To go as far as their drive will take them. See this take shape on the INFINITI Q50, where digitally enhanced dynamics amplify its segment-leading power. Begin by crafting your Q50 for your unlimited journey. Every selection will transform vision into reality: Yours.



REFLECT YOUR NATURAL POWER Sharpened lines, intensified headlights and dramatized taillights distinguish the restyled front and rear of the INFINITI Q50. To make your most powerful statement, the Q50 RED SPORT 400 front fascia bears bold edges and aggressive openings that are complemented by a rear bumper with aero-inspired lower diffuser.

ACCELERATE TO THE REDLINE The INFINITI Q50 can thrill you with a range of engines that unleash the forces of innovation to heighten your performance, including a pair of 3.0-liter twin-turbo V6 engines. For the peak experience is the segment-leading 400 HP variant in the Q50 RED SPORT 400 models, with its signature red "S" badging.



ENHANCE YOUR CAPABILITIES

How will your Q50 come to life? Engineered to amplify the driver, it offers bold ideas for the driven. Tailor the interior to your personality. Accent the space to your taste. Lead with technologies that challenge conventions of what a sport sedan—and you as its driver—can achieve.

PILOT WITH EASE When technology advances to enhance the driver, you can cruise easier, follow smarter, steer quicker. INFINITI drive assist technologies in the ProACTIVE Package employ the same technical innovations that will inspire and empower us in the future. When activated, drive assist technologies can automatically react to traffic, to help you brake for cars ahead, accelerate to your preset pace, and even help steer straight down your lane.

DRIVE WITH BACKUP Equip yourself with the most advanced safety technologies to help you see and respond to danger. Predictive Forward Collision Warning enables your Q50 to monitor the vehicle in front of you and the one in front of that one. Equally forward-looking, the Around View® Monitor with Front and Rear Parking Sensors offers a virtual 360-degree view from above to make parking easier.

SENSE THE DIFFERENCE Watch as the seats and steering wheel automatically move to your precise settings. Hear, for yourself, the full precise sound of the Bose® Performance Series audio system.



YOUR EXHILARATION. Q50 RED SPORT 400

The feeling is limitless. The sense of power is like an endless flood. Then you open your eyes and look around. Yes, you are sitting inside a vehicle that epitomizes heightened performance. Yet human artistry surrounds you. Starting with the aesthetic of red-stitched semi-aniline leather-appointed seats, extending to the tactile sense of deep-quilted surfaces and progressing to the modern feel of dark-finished accents, this is design that elevates. Inspires. Emboldens.



TRIM LEVELS & PACKAGES

Q50 2.0T LUXE AND Q50 2.0T SENSORY WITH PROACTIVE

- 208-hp 2.0-liter I4 turbo
- Rear-Wheel Drive
- 7-speed Automatic Transmission
- LED signature headlights
- INFINITI InTouch™ dual screen display
- INFINITI Intelligent Key with Push Button Start
- INFINITI Drive Mode Selector (Standard, Sport, Snow, Personal)
- Bluetooth® Hands-free Phone System and audio streaming
- Power sliding, tinted glass moonroof, piano black interior trim
- 8-way power driver & front passenger seats with adjustable lumbar support for driver
- Dual Zone Automatic Temperature Control System
- 2 USB ports
- INFINITI studio 6-speaker sound system, CD/DVD, speed-sensitive volume

Additional features in the Q50 2.0T Sensory with ProACTIVE:

- Eco Pedal
- Intelligent Cruise Control
- Navigation System
- Adaptive LED front headlights with LED daytime running lights
- High beam assist with auto dimming function
- Bose® Performance Series, 16-speaker premium audio system, CD/DVD & speed-sensitive volume
- INFINITI ProACTIVE (Lane Departure Warning, Blind Spot Warning, Forward Collision Warning, Back-up Collision Intervention)
- Around View® Monitor

Q50 RED SPORT 400

- 400-hp 3.0-litre V6 twin-turbo
- Rear-Wheel Drive
- 19-inch aluminium alloy wheels with 245/40R19 run-flat performance tyres
- Dynamic Digital Suspension
- Direct Adaptive Steering
- Intelligent Cruise Control
- INFINITI Drive Mode Selector (Standard, Eco, Snow, Personal, Sport & Sport+)
- Sport brakes with red finish calipers
- Dual exhaust tips with brushed satin finish
- Red "S" exterior badging and Black-painted sideview mirrors
- Quilted, semi-aniline leather-appointed sport seats with red stitching
- Steering wheel-mounted paddle shifters
- Black headliner and pillars
- Aluminum sport pedals
- Blind Spot Warning (BSW)
- Backup Collision Intervention (BCI)
- Around View® Monitor (AVM) with Moving Object Detection (MOD) with Front and Rear Parking Sensors
- Predictive Forward Collision Warning (PFCW)
- Forward Emergency Braking (FEB)



WHEEL CHOICES



18 X 7.5-INCH ALUMINIUM-ALLOY WHEELS WITH ALL-SEASON RUN-FLAT TYRES



19 X 8.5-INCH ALLUMINIUM ALLOY WHEELS WITH RUN-FLAT PERFORMANCE TYRES

INTERIOR COLORS



INTERIOR TRIM

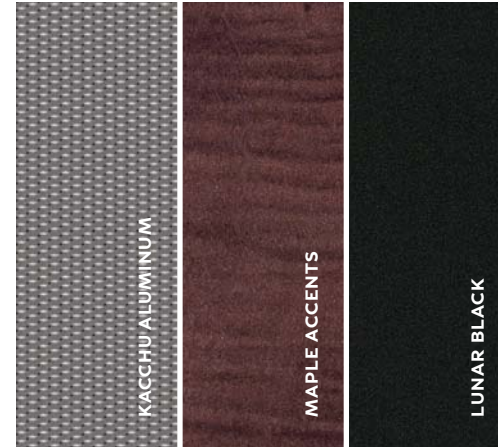

EXTERIOR COLORS



INFINITI has taken care to ensure that the color swatches presented here are the closest possible representations of actual vehicle colors. Swatches may vary slightly due to the printing process and whether viewed in daylight, fluorescent or incandescent light. Please see the actual colors at your local INFINITI Retailer.

TECHNICAL SPECS

EXTERIOR DIMENSIONS

Coefficient of drag – Q50 2.0T Luxe / 2.0T Sensory with ProACTIVE / Red Sport 400 0.26 / 0.29

Turning diameter (feet) – RWD 36.7

INTERIOR DIMENSIONS

Cargo volume (litres) for all variants 510

Headroom with moonroof – Front / Rear 1,003 / 934

Legroom (mm) – Front / Rear 1,130 / 891

Passenger volume with moonroof (litres) 100

WEIGHT AND CAPACITY

Q50 2.0T Luxe / 2.0T Sensory with ProACTIVE / Red Sport 400 1,656 / 1,740

Fuel capacity (litres) for all variants 80

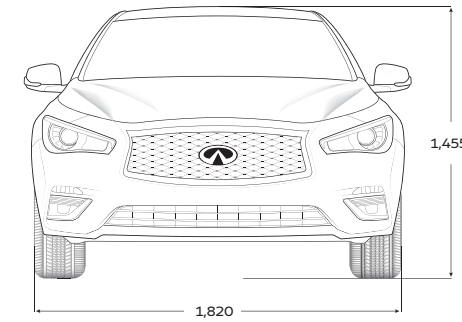

All dimensions are measured in mm.

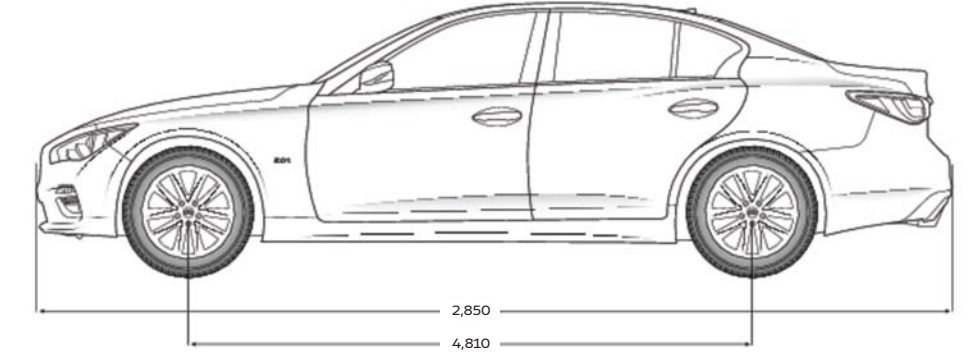

This brochure is intended for general descriptive and informational purposes only. It is subject to change and does not constitute an offer, representation or warranty (express or implied) by INFINITI Singapore. Interested parties should confirm the accuracy of any information in this brochure as it relates to a vehicle directly with INFINITI Singapore before relying on it to make a purchase decision. INFINITI Singapore reserves the right to make changes, at any time, without prior notice, in prices, colors, materials, equipment, specifications, and models and to discontinue models or equipment. Due to continuous product development and other pre- and post-production factors, actual vehicle, materials and specifications may vary from this brochure. Some vehicles shown with optional equipment. See the actual vehicle for complete accuracy. Availability and delivery times for particular models or equipment may vary.

• Cargo and load capacity limited by weight and distribution. Always secure all cargo. Heavy loading of the vehicle with cargo, especially on the roof, will affect handling and stability of the vehicle. • AVM with MOD cannot completely eliminate blind spots and may not detect every object. MOD operates at vehicle speeds below 8 km/h. Always check surroundings and turn to look behind you before moving vehicle. • The Sonar System is a convenience, not a substitute for proper parking and/or backing procedures. Always check that it is safe to do so before moving vehicle. May not detect every object. • MOD cannot completely eliminate blind spots and may not detect every object. MOD operates at vehicle speeds below 8 km/h. Always check surroundings and turn to look behind you before moving vehicle. • Intelligent Park Assist is only an aid. It is not a substitute for your attention to the immediate surroundings. The responsibility for safe maneuvering and parking the vehicle remains with the driver. • Parking aid/convenience feature. Cannot completely eliminate blind spots. May not detect every object and does not warn of moving objects. Always check surroundings and turn to look behind you before moving vehicle. • Driving is serious business. Only use INFINITI InTouch Services and INFINITI InTouch Services Premier when safe to do so. Never program while driving. GPS mapping may not be detailed in all areas or reflect current road status. Services, including Automatic Crash Notification and Emergency Call, require an active subscription, and are dependent upon the telematics device being in an operative condition, its ability to connect to a wireless network, compatible wireless network availability, navigation map data, and GPS satellite signal receptions, the absence of which can limit or prevent the ability to reach INFINITI InTouch Services Customer Care or receive support. 3G cellular network not available in all areas and/or available at all times. Cellular technology is evolving, and changes to cellular networks provided by independent companies are not within INFINITI's control. Certain vehicle services, including Google® compatible services, provided by independent companies are not within control and are subject to change without notice or liability to INFINITI, its affiliates and agents. Like other devices that rely on network coverage, once the network service is discontinued, INFINITI InTouch services will not function without equipment replacements, upgrades, or alternative network coverage, which INFINITI can guarantee. INFINITI is not responsible for associated costs that may be required for continued operation due to cellular network shutdown or discontinuation (including equipment upgrades, if available, or roaming charges on alternative networks). • Driving is serious business and requires your full attention. If you have to use the connected device while driving, exercise extreme caution at all times so full attention may be given to vehicle operation. iPod is a registered trademark of Apple Inc. All rights reserved. iPod™ not included. • Availability of specific features is dependent upon the phone's Bluetooth® support. Please refer to your phone Owner's Manual for details. Bluetooth word mark and logos are owned by Bluetooth SIG, Inc., and any use of such marks by INFINITI is under license. • ITPMS is not a substitute for regular tire pressure checks. • Blind Spot Warning is not a substitute for proper lane change procedures. The system will not prevent contact with other vehicles or accidents. It may not detect every vehicle or object around you. • Lane Departure Warning System operates only when the lane markings are clearly visible. Speed limitations apply. See Owner's Manual for details. • FEB cannot prevent accidents due to carelessness or dangerous driving techniques. It may not provide warning or braking in certain conditions. Speed limitations apply. • Cruise Control is not a collision avoidance system or warning device. Designed to use limited braking. Failure to apply the brakes could result in an accident.

Bose is a registered trademark of Bose Corporation. Bluetooth is a registered trademark of Bluetooth SIG, Inc.



INFINITI

EMPOWER THE DRIVE

www.infiniti-singapore.com

 [Facebook.com/InfinitiSG](https://www.facebook.com/InfinitiSG)

 [infinitisingapore](https://www.instagram.com/infinitisingapore)



WEARNES 45 Leng Kee Road, Singapore 159103 Tel: 6430 4840

This brochure is intended for general descriptive and informational purposes only. It is subject to change and does not constitute an offer, representation or warranty (express or implied) by INFINITI Singapore. Interested parties should confirm the accuracy of any information in this brochure as it relates to a vehicle directly with INFINITI Singapore, before relying on it to make a purchase decision. INFINITI Singapore, reserves the right to make changes, at any time, without prior notice, in prices, colours, materials, equipment, specifications and models and to discontinue models or equipment. Due to continuous product development and other pre- and post-production factors, actual vehicle, materials and specifications may vary from this brochure. Some vehicles are shown with optional equipment. See the actual vehicle for complete accuracy. Availability and delivery times for particular models or equipment may vary.

For additional information on availability, options or accessories, contact INFINITI Singapore.